

Barnes & Jones

Float & Thermostatic Steam Traps Series 2000 (VAC-30 PSIG)

Features

- Variety of hook-up combinations
- Unaffected by sudden or wide pressure changes
- Responds quickly to condensate load changes
- Continuous discharge
- Condensate discharge temperature closely follows the saturated steam curve
- Function is not impaired by high back pressure
- Energy efficient
- Simple construction
- On-line repair

Description

The Barnes & Jones float and thermostatic traps, Series 2000 are designed for all types of low pressure or vacuum steam heating systems and steam process equipment. Typical applications include; unit heaters, space heaters; water heaters, pressing machines and low pressure mains and risers.

Float and thermostatic traps are specially well suited for apartments, hospitals, office buildings and schools or wherever quiet operation is necessary.

Operation

The opening and closing of the valve is caused by changes of the condensate level within the trap shell.

When the water level drops, the weight of the float closes the valve. As condensate enters the traps, the



float rises and opens the valve, allowing condensate to be discharged. The float is designed to provide sufficient buoyancy to overcome the differential pressure across the valve. The internal float and valve configuration is such that the condensate level is always above the valve, creating a continuous water seal at the seat.

Air and other gasses are freely discharged as they reach the trap through the air vent. The calibrated thermostat will close the air vent immediately when the temperature surrounding the element reaches saturated steam temperature.

Construction

Barnes & Jones float and thermostatic traps are compact, of rugged design, with easy access to all interior parts. The body is cast with two inlet and two outlet pipe connections that permit four combinations of pipe hook-ups for all types of applications.* All working parts are made of corrosion resistant materials and attached to the cover casting. The repair kit consists of a complete, factory assembled head which simply bolts on for ease of repair.* No pipe connections need to be broken.

*except the 2" model which is piped through the head.

MATERIALS

Part	Description
Head	Cast Iron, ASTM-A278 Class 30
Body	Cast Iron, ASTM-A278 Class 30
Bolting	Steel, Grade 5
Gaskets	Non-Asbestos Fiber
Float	Stainless Steel
Plug	Stainless Steel
Seat	Brass, 15#; Stainless Steel, 30#

Engineering Specifications

CAPACITIES (SHEMA)

lbs. condensate per hour.

Pipe Size	Model No.	Pressure Differential (PSIG)						
		1/4	1/2	1	2	5	10	15
3/4"	FT2015-3	70	100	140	200	210	220	230
1"	FT2015-4	175	250	350	500	525	550	575
1 1/4"	FT2015-5	425	600	850	1200	1260	1320	1380
1 1/2"	FT2015-6	850	1200	1700	2400	2520	2640	2760
2"	FT2015-8	1775	2500	3550	5000	5250	5500	5750

Note on capacity: Low pressure F & T Trap capacities are in accordance with standard adopted by the Steam Heating Manufacturer's Association (SHEMA) providing for the continuous elimination of air when the trap is operating at its maximum rating. No Safety factor need be applied. Actual capacities are significantly greater than the SHEMA rating indicate.

CAPACITIES (Gross)

lbs. condensate per hour.

Pipe Size	Model No.	Pressure Differential (PSIG)									
		1/4	1/2	1	2	5	10	15	20	25	30
3/4"	FT2015-3	293	387	513	683	824	1050	1129	-	-	-
1"	FT2015-4	293	387	513	683	824	1050	1129	-	-	-
1 1/4"	FT2015-5	630	808	1029	1302	1722	2100	2457	-	-	-
1 1/2"	FT2015-6	1155	1785	2520	3465	5250	6930	7980	-	-	-
2"	FT2015-8	2415	2940	3780	4883	7245	9450	11445	-	-	-
3/4"	FT2030-3	293	387	513	683	824	1050	1129	1271	1365	1439
1"	FT2030-4	293	387	513	683	824	1050	1129	1271	1365	1439
1 1/4"	FT2030-5	394	525	725	956	1260	1575	1764	1890	1995	2100
1 1/2"	FT2030-6	1050	1365	1785	2415	3570	4830	5775	6300	6930	7350
2"	FT2030-8	1365	1890	2625	3570	5460	7140	8190	9030	9765	10500

Note on capacity: Trap capacities are based on continuous discharge at steam temperature. The published figures are the result of an extensive testing program conducted in accordance with ANSI/ASME PTC 39.1 - 1980, *Condensate Removal Devices for Steam Systems*, at the B & J factory. Significantly greater capacities are realized when condensate temperature is below saturated steam temperature. Appropriate safety factors should be applied to these ratings.

NOTE: FLOAT TRAPS are available for those applications where draining liquid is the only requirement of the trap. In those instances the thermostatic air vent is replaced by a solid plug. To order, use the previous model numbers with the prefix "F" instead of "FT". All pipe sizes and pressure ratings are available.

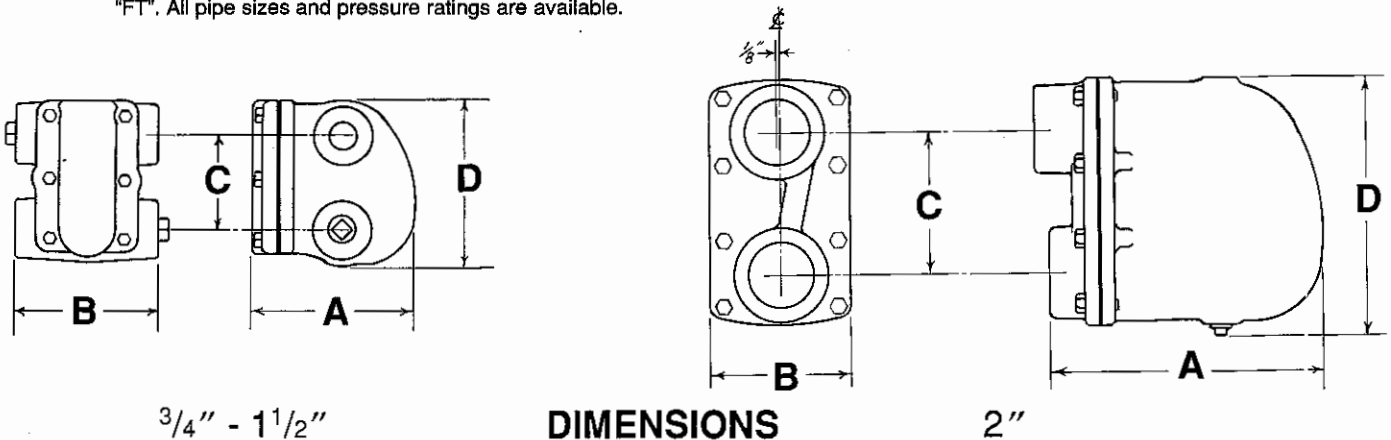

Size	Models	A	B	C	D	WT.
3/4"	FT2015-3, FT2030-3	5 1/16	5	3 7/16	5 5/8	11 lbs.
1"	FT2015-4, FT2030-4	5 1/16	5	3 7/16	5 5/8	11 lbs.
1 1/4"	FT2015-5, FT2030-5	6 1/8	5 1/2	3	5 5/8	12 lbs.
1 1/2"	FT2015-6, FT2030-6	8 1/4	6	3	8 1/4	24 lbs.
2"	FT2015-8, FT2030-8	10	4 7/8	4 7/8	9 1/4	22 lbs.